

## PAD-STAR® DC ELEVATED POLE MOUNT - 2ND GENERATION

### HP2000 SERIES



**AC POLE MOUNTED  
PERIMETER LIGHT**

*HP0270 Pole Optional. Pole not included.*

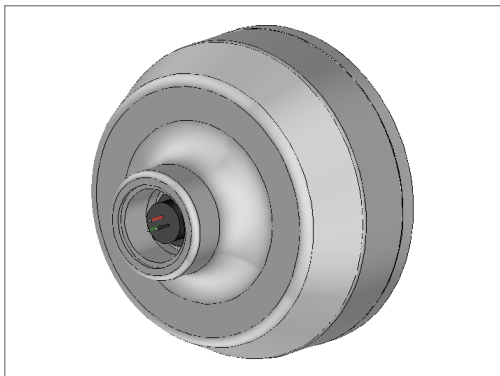

[View Interactive 3D Image](#)  
*Must use Adobe Reader or Acrobat*

This newly redesigned Pole perimeter light is the latest addition to the FEC Heliports line of high quality LED lights.

Perimeter and Obstruction lights are one of the most important safety features on your heliport. They are used to mark and illuminate the FATO, TLOF, and Obstructions as well as to help the pilot locate the pad and safely land during night operations and inclement weather conditions.

### Key Features:

- Hermetically sealed optical assembly to mitigate condensation
- Infra-Red equipment standard on all PadStar Series lighting
- NVG Compatible
- 10-Year Limited Warranty
- Engineered and designed to be universally compatible with any existing heliport lighting system
- Mil-spec anodized cast aluminum body suitable for the harshest environments
- Pre-wired for quick and easy installations

## Technical Details

### Operating Voltage:

- 12/24 VDC input from FEC Controllers

### Operating Power:

- 6 Watts @ 0.350ma

### Operating temperature:

- - 40°f to 131°f
- - 40°c to + 55°c

### Operating Lifespan:

- LED's Rated to 50,000 hrs

### Light Source:

- 1x Osram Visible LED
- 3x Osram IR Diodes

### Standard Part Numbers:

- HP2160P True Green (528nm)
- HP2163P Blue (470nm)
- HP2161P White 6000K
- HP2162P Yellow/Amber (590nm)
- HP2180P Red

## PAD-STAR® DC ELEVATED POLE MOUNT - 2ND GENERATION

### Photometric:

Standards  
U.S. Department of Transportation, Federal Aviation Administration,  
Memorandum, Heliport Perimeter Light for Visual Meteorological  
Conditions. Engineering Brief No. 87

Parameter	Requirement	Measured	Result
Min. Peak Intensity	5 cd from 16° - 90°	12.6 cd	Pass
Min. Peak Intensity	10 cd from 0° - 15°	23.3 cd	Pass
Min. Avg Intensity	15 cd from 0° - 15°	46.7 cd	Pass

cd = Candela

### Standards

Internal Civil Aviation Organization (ICAO):  
Aerodromes, Annex 14, Volume 2, Fourth Edition, dated July 2013  
Aerodromes, Annex 14, Volume 1, Seventh Edition, dated July 2016

Parameter	Requirement	Measured	Result
Min. Peak Intensity	3 cd from 21° - 90°	12.6 cd	Pass
Min. Peak Intensity	8 cd from 13° - 20°	36.1 cd	Pass
Min. Peak Intensity	15 cd from 11° - 13°	51.5 cd	Pass
Min. Peak Intensity	30 cd from 6° - 10°	41.7 cd	Pass
Min. Peak Intensity	15 cd from 2° - 5°	30.9 cd	Pass

Test Purpose - Performance Testing (Photometry and Chromaticity)

Test Dates - December 11, 2018

### Standards & Certification:

- ETL Listed to UL2108
- ETL Listed to UL1598 at -40° c to +55°c
- ETL Listed to CSA C22.2 NO. 250.0-08
- FAA EB#87, L-860HR & HS
- FAA AC 150/5390-2 (Latest Rev.), Heliports Design Guide
- ICAO Annex 14, Volume II
- UK CAP 437
- UK CAP 1264

### Physical Characteristics

#### Light Fixture:

##### Dimensions:

- Height 5 inches(127mm)
- Lid Diameter 6-1/2 inches(165.1mm)

##### Materials:

- Lens Tempered Glass
- Casting 356 T6 Aluminum Alloy

Notes: All machining on the Aluminum casting is done in house by FEC Heliports

#### Mounting:

- 1"(25.4mm) NPT located on the bottom of each pole light

##### Materials:

- Casting 356 T6 Aluminum Alloy
- Notes: All machining on the Aluminum casting is done in house by FEC Heliports
- Light: 6lbs.

### Pole Mounting Details

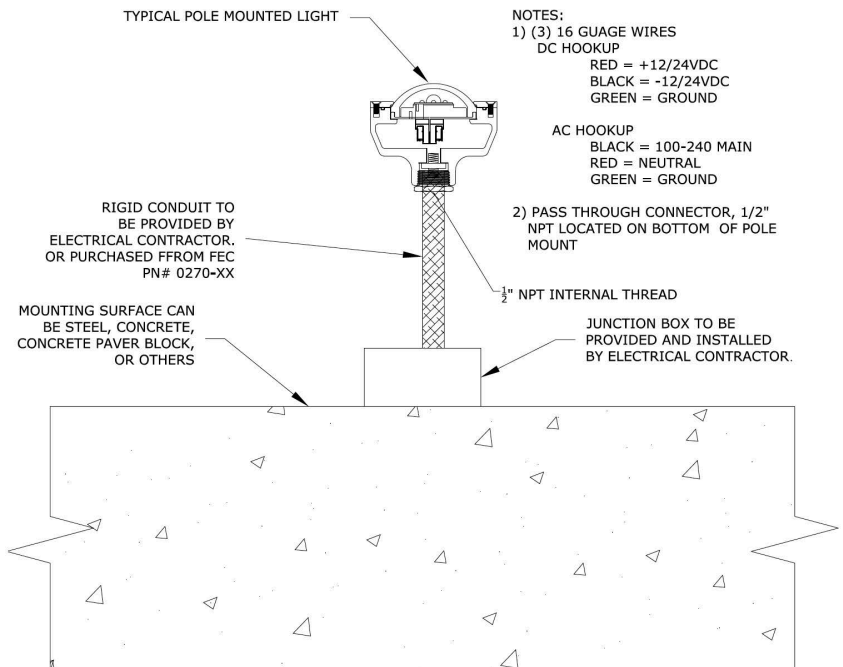

## WHAT TO DO IF YOU DO NOT SEE THE IMAGE:

To View the interactive 3D image:

- Click *OPTIONS* in the yellow bar above (see screen shot below)
- Select *TRUST THIS DOCUMENT ALWAYS* to always see the image when opening this file
- Click [HERE](#) to view the interactive image

